



CURVADORA MANUAL / ROUND BENDING MACHINE / CINTREUSE TUBE MANUELL

- Construcción en acero fundido.
- Ejes y rodillos en acero templado, endurecidos y rectificadas.

Referencia / Reference / Référence

FTX-10-CPM

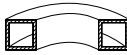
500391005

Tamaño Máx. mm. Max. Size mm. Dimension Max.	
	Ø externo 21,4mm
	Ø externo 26,7mm
	Ø externo 33,4mm
	Ø externo 48,3mm
	Ø externo 15,9mm
	Ø externo 19,05mm
	Ø externo 22,2mm
	Ø externo 25,4mm
	Ø externo 28,6mm
	Ø externo 31,8mm
	Ø externo 34,9mm
	Ø externo 38,1mm
	Ø externo 44,5mm
	Ø externo 50,8mm
	20x5 30x10 19,05x19,05 25,4x25,4 38,1x38,1
	20x5 50x10
	10x10 20x20
Trabajo que se puede realizar con los rodillos estándar Work that can be done with standard rollers Travail qui peut être fait avec des galets standard	



FTX-10-CPM

Ø Husillo / Shaft diameter / diamètre de l'arbre	mm	30
Ø Rodillo superior / Upper roll diameter / Rouleur supérieur	mm	98
Ø Rodillo inferior / Lower roll diameter / Rouleur inférieur	mm	118
Peso Neto-Bruto / Net-Gross weight / Poids Net-Brut	Kg.	153 / 170
Dimensiones / Dimensions / Dimensions	mm.	500x480x680 / 870x770x340



8423640500570